

MSC FILTRATION TECHNOLOGIES

FILTRATION EQUIPMENT PUMPS SERVICES

WWW.MSCFILTERTECH.COM

198 Freshwater Blvd., Enfield, CT 06082
(860) 745-7475 Fax: (860) 745-7477

SERVICE MANUAL PSK Pumps 2-15gpm

DESIGN FEATURES

Housing: Cast Iron
Pump Rotor: Chrome Plated AISI 416
Stainless Steel
Pump Stator: NBR (Nitrile)
Seal: Mechanical (carbon/ceramic)
Motor Shaft: AISI 416 ss
Motor: 1/2 HP, 60 Hertz, 1725rpm,
totally enclosed, fan cooled (TEFC) C-faced,
1 phase, 115/230V or 3 phase, 230/460V
(other motor options available)
(consult sales representative)

Note: Alternate elastomers available

INSTALLATION

Mounting Position. Pump may be mounted in any position. When mounting vertically, it is necessary to keep bearings above seals to prevent possible seal leakage into bearings.

Pre-Wetting. Prior to connecting pump, wet pump elements and mechanical seal by adding fluid to be pumped into suction and discharge ports. Turn pump over several times in a clockwise direction to work fluid into pump elements.

Piping. Piping to pump should be self-supporting to avoid excessive strain on pump housing. See Table 1 for suction and discharge port sizes of each pump model. Use pipe "dope" or tape to facilitate disassembly and to provide seal on pipe connections.

Electrical. Follow the wiring diagram on the motor nameplate or inside the terminal box for the proper connections. The wiring should be direct and conform to local electrical codes. Check power connections for proper voltage. Voltage variations must not exceed $\pm 10\%$ of nameplate voltage. Motor is provided with internal automatic overload protection.

OPERATION

Self-Priming. With wetted pumping elements, the pump is capable of 25ft of suction lift with pipe size equal to port size. *Be sure suction lines are air tight or pump will not self prime.* Self-priming capabilities will vary due to fluid viscosity.

The pump MUST be primed before initial start-up, and CANNOT be run dry.

To prevent damage to pump, pump rotation must be CLOCKWISE when facing pump from motor end.

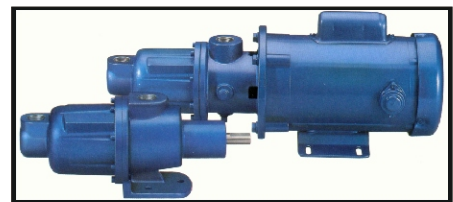

PSK Model Pump

DO NOT RUN DRY. Unit depends on liquid pumped for lubrication. For proper lubrication, flow rate should be at least 20% of rated capacity.

Pressure and Temperature Limits. See Table 1 for maximum discharge pressure of each model. Unit is suitable for service at temperature shown in Table 2.

Caution-Suction pressure should never be greater than discharge pressure.

Table 1 - Pump Data

Pump Model	Suction Port (NPT)	Discharge Port (NPT)	Voltage Rating (VAC)	Discharge Pressure (PSIG)
PKR-2	3/4"	3/4"	115/230 230/460	150
PKR-4,6	3/4"	3/4"	115/230 230/460	100
PKR-9	3/4"	3/4"	115/230 230/460	50
PKR-15	3/4"	3/4"	115/230 230/460	50

Table 2 - Temperature Limits

Elastomer	Temperature Limits
*NBR	10° - 160° F
*EPDM	10° - 210° F
*FPM	10° - 240° F

*NBR = Nitrile

*EPDM = Ethylene-Propylene-Diene Terpolymer

*FPM = Fluoroelastomer

Warning!!

Before making adjustments, disconnect power source and thoroughly bleed pressure from system before disassembly. Failure to do so could lead to electric shock or serious bodily harm.

TROUBLESHOOTING

Failure to Pump

1. Motor will not start: Check power supply. Voltage must be $\pm 10\%$ of nameplate rating when motor is in locked rotor condition. Check for faulty capacitor on 1 phase models.
2. Motor runs and thermally kicks out: Check for excessive discharge pressure. Check for defective centrifugal switch on 1 phase models. Increase ventilation to motor. Do not use less than #14 wire size.
3. Stator torn: Possible excessive pressure. Replace stator, check pressure at discharge port.
4. Flexible (apex) joint broke: Possible excessive pressure. Replace joint, check pressure at discharge port.
5. Wrong rotation (3 phase only): Rotation must be clockwise when facing pump from motor end. Reverse the connections of any two line leads to the motor.
6. Excessive suction lift or vacuum.

Pump Overloads

1. Excessive discharge pressure: Check pressure at discharge port for maximum ratings given in Table 1.
2. Fluid viscosity too high: Limit fluid viscosity to 100 CP or 500 SSU.

Noisy Operation

1. Excessive suction lift or vacuum: Maximum suction lift is 25ft of water.
2. Suction line too small: Check pipe size. Be sure lines are free from obstructions.
3. Pump Cavitates: Pump speed is 1725 rpm. Viscosity of fluid should not exceed 100 CP or 500 SSU.
4. Flexible joint worn: Replace joint. Check pressure at discharge port.
5. Insufficient mounting: Mount to be secure to a firm base. Vibration induced noise can be reduced by using mount pads and short sections of hose on suction and discharge ports.

Seal Leakage

1. Leakage at startup: If leakage is slight, allow pump to run several hours to let faces run in.
2. Persistent seal leakage: Faces may be cracked from freezing or thermal shock. Replace seal.

Pump Will Not Prime

1. Air leak on suction side: Check pipe connections.

PUMP DISASSEMBLY

1. Remove suction and discharge piping. Drain pump body by removing drain plug.
2. Remove screws (7) holding suction housing to discharge housing. Remove suction housing and stator (5).
3. Remove rotor (4) from flexible joint (3) by turning counterclockwise (RH thread). On pinned, 3 phase models, remove rotor pin (2) with suitable punch.
4. Flexible joint (3) can be removed from motor shaft by using a 3/16" allen wrench in end of joint and turning counterclockwise. On 3 phase motors, remove motor pin (2) with suitable punch, then remove joint.
5. Slide mechanical seal (1) off motor shaft.
6. Remove discharge housing from adapter flange by removing screws (7).
7. Carefully pry seal seat out of discharge housing. If any parts of mechanical seal are worn or broken, the complete seal assembly should be replaced. Seal components are matched parts and are not interchangeable.
8. Remove adapter flange from motor by removing screws (7).
9. Remove Slider ring.

PUMP ASSEMBLY

1. Install slinger ring.
2. Attach adapter flange to motor housing using screws (7).
3. Attach discharge housing to adapter flange using screws (7). Be sure to center seal bore on shaft.
4. Install mechanical seal (1) in the discharge housing using the following procedure:
 - A/ Clean and oil sealing faces using clean oil (not grease)
Caution: Do not use oil on EPDM parts. Substitute glycerin or soap and water.
 - B/ Oil outer surfaces of the seal seat, and push assembly over the motor shaft and into the discharge housing seating it firmly and squarely.
 - C/ After cleaning and oiling the shaft, slide the seal body along the motor shaft until it meets the seal seat.
 - D/ Install seal spring and spring and spring retainer on shaft.
5. Thread flexible joint (3) into motor shaft in a clockwise direction (RH thread). Tighten with 3/16" allen wrench. On 3 phase models, install motor pin (2).
6. Thread rotor (4) onto flexible joint (3) in a clockwise direction (RH thread). On 3 phase models, install rotor pin (2).
7. Slide stator (5) on rotor (4). On 2 and 4 gpm pumps, insert rounded end of stator ring into end of stator prior to installing stator on rotor.
8. Secure stator (5) and suction housing to discharge housing using screws (7).
9. Lubricate rotor and stator by filling suction housing and discharge housing with fluid to be pumped.
10. Connect suction and discharge piping and power source.

MSC FILTRATION TECHNOLOGIES

FILTRATION EQUIPMENT PUMPS SERVICES

WWW.MSCFILTERTECH.COM

198 Freshwater Blvd., Enfield, CT 06082

(860) 745-7475 Fax: (860) 745-7477

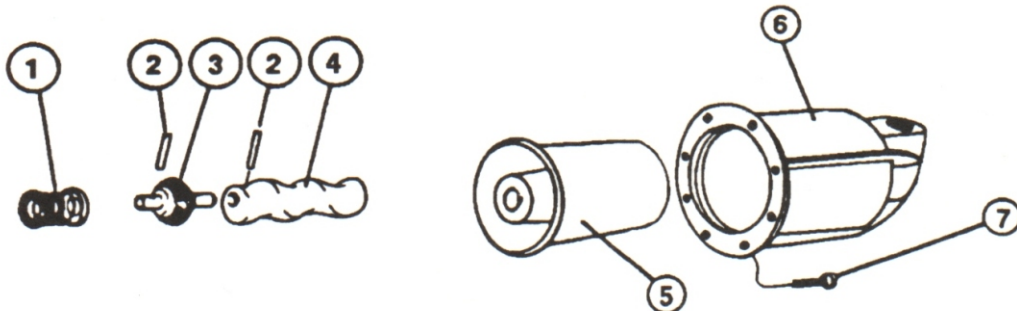
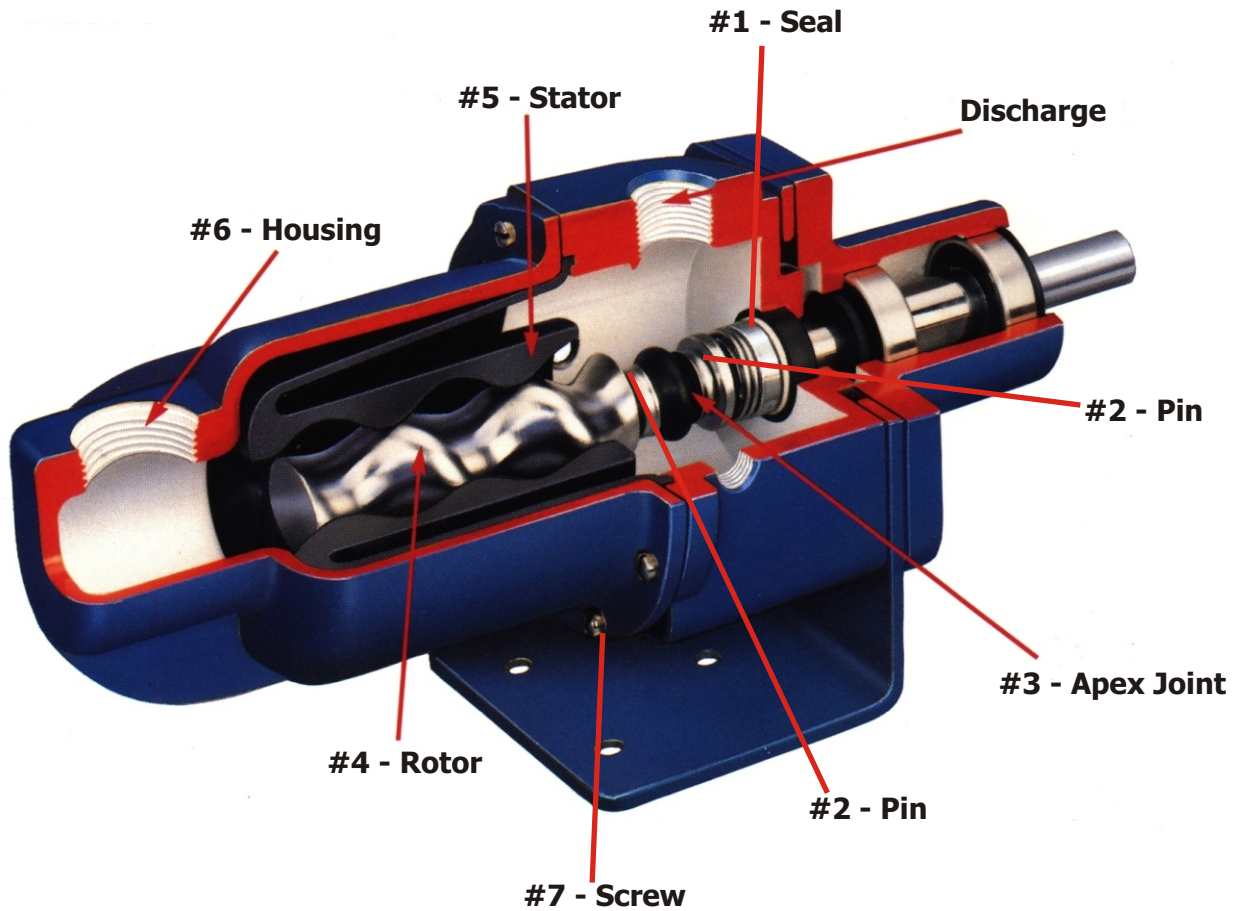

**To Order Correct Replacement Parts
Use Pump Model Number**